

TIG Brush™

Stainless Steel Weld Cleaning System

Operation, Safety and Maintenance Manual



STOP!

**Online warranty activation
required before first use**

www.tigbrush.com/warranty

FOREWORD

FOREWORD

This manual is a very important tool! Keep it with the machine at all times.

The purpose of this manual is to provide users with the necessary operating procedures and precautions, essential for the safe and proper operation of the TIG Brush.

Due to continuous improvements, Ensitech Pty Ltd reserves the right to make specification changes.

© 2018 Ensitech Pty Ltd

FOREWORD

SAFETY ALERT SYMBOLS AND SAFETY SIGNAL WORDS



WARNING

THIS IS THE SAFETY ALERT SYMBOL. IT IS USED TO ALERT YOU TO THE POTENTIAL PERSONAL INJURY HAZARDS. OBEY ALL SAFETY MESSAGES THAT FOLLOW THIS SYMBOL TO AVOID POSSIBLE INJURY.



CAUTION

INDICATES AN IMMEDIATELY HAZARDOUS SITUATION. IF NOT AVOIDED, MAY RESULT IN MINOR OR MODERATE INJURY. IT MAY ALSO ALERT AGAINST UNSAFE PRACTICES.



THIS SYMBOL INDICATES A HAZARDOUS SUBSTANCE WHICH MAY CAUSE MINOR OR MODERATE INJURY. SOME TIGBRUSH KITS MAY SHIP WITH HAZARDOUS FLUIDS. CHECK SAFETY DATA SHEETS CAREFULLY.



SYMBOL FOR "VOID WARRANTY" OR "DAMAGED WORK"

FOREWORD

FOR:

- Accident reporting
- Product safety publications
- Current owner updates
- Questions regarding product safety
- Standards and regulations compliance information
- Questions regarding special product applications
- Questions regarding product modifications

CONTACT

Your local TIG Brush distributor.

www.tigbrush.com



Ensitech Pty Ltd
Unit 1/144 Old Bathurst Road
Emu Plains NSW 2750
Australia

Phone: +61 2 4735 7700
Email: info@ensitech.com.au

REVISIONS LOG

REVISIONS LOG

Original Issue of Manual: August 2016.

Revision 1: April 2018.

CONTENTS

S1	INTRODUCTION	9
S2	SAFETY PRECAUTIONS	10
S3	DESCRIPTION OF APPARATUS	12
S4	OPERATION	14
	4.1 Preparation	14
	4.2 Assembly	14
	4.3 Cleaning Fluid	14
	4.4 Operation	16
S5	POWER AND GRADE SETTING	17
	5.1 Power Settings	17
	5.2 Mode Settings	17
S6	MAINTENANCE	18
S7	CONSUMABLES	19
	7.1 Brushes	19
	7.2 Insulating Shroud	19
	7.3 Fluids	
	• Pre-Weld Cleaning Fluids	19
	• Cleaning Fluids	19
	• Neutralising Fluids	19
	• Finishing Fluid	19
	• Marking Fluids	19
	• Etching Fluids	19
S8	TROUBLESHOOTING	20
	8.1 Front Panel Power Light Not Illuminated	20
	8.2 Front Panel Power Light Illuminated & Unit Not Operating	21
S9	WARRANTY	22

S1 INTRODUCTION

INTRODUCTION

The TIG Brush™ is a metal cleaning/polishing system created by Ensitech Pty Ltd.

It uses the combined action of an electric current, heat and proprietary fluid to remove heat marks and other surface contaminants from metal surfaces.

Various models allow Ensitech to tailor a solution for you whether you use MIG, TIG or most other methods of welding stainless steel. Surface impurities can also be removed from other metals such as aluminium, brass and copper.

Several cleaning solutions are available, each suited to different applications. Contact Ensitech for more information, or visit our website **www.tigbrush.com**

S2 SAFETY PRECAUTIONS

SAFETY PRECAUTIONS

Protect yourself and others by observing all safety information, warnings and cautions. Failure to comply with instructions could result in personal injury and/or damage to the product or property.

Read this documentation carefully before operating the equipment. Please retain these instructions for future reference.

Before using the TIG Brush, make sure the work environment is well ventilated and away from any combustible substances. Ensure that all required equipment is available.



WARNING

Do not use the TIG Brush for any purpose other than that described in this manual. Failure to observe this warning may result in permanent damage to the TIG Brush, cause damage to the workpiece, cause injury to the operator and void the warranty.

SAFETY INFORMATION

The TIG Brush is one of the safest appliances in its class. However some precautions must be taken with the use of the TIG Brush, as with any electro-cleaner.

- The TIG Brush uses mild acids; gloves should be used to avoid prolonged contact with any of the fluids.
- Goggles should be worn to prevent fluid being splashed in the eyes.
- Where an inhalation risk exists, wear a type B (Inorganic gases & vapours) respirator.

S2 SAFETY PRECAUTIONS

- Fluid spilled on the skin should be washed off as soon as practical.
- Safety Data Sheet is available for all fluids and should be read before use.
- The brush gets extremely hot, in excess of 200°C degrees centigrade. Be very careful touching the brush. Do not place the brush near any flammable materials.
- The TIG Brush produces an electric current which may generate small sparks between the brush and the metal being cleaned.
- Hydrogen gas may also be generated (which is an invisible but explosive gas). Always use the apparatus in a well ventilated area. Do not use near flammable substances, or in areas where dense flammable gases (such as petrol vapour) may accumulate.
- If the power cord is damaged or if the TIG Brush has been dropped from a height and damaged, do not use the unit. Contact your TIG Brush supplier to have the TIG Brush inspected and repaired.
- Do not short out the terminals, or use the TIG Brush with a damaged wand or cables. Doing so may permanently damage the TIG Brush and cause damage to the workpiece being cleaned. The high currents involved may also cause intense heating of the shorted or damaged part, which could result in burns to the operator.
- Ensure that the TIG Brush is located where it cannot easily fall and cause injury. Ensure that the cables do not present a trip hazard.



S3 DESCRIPTION OF BASIC APPARATUS

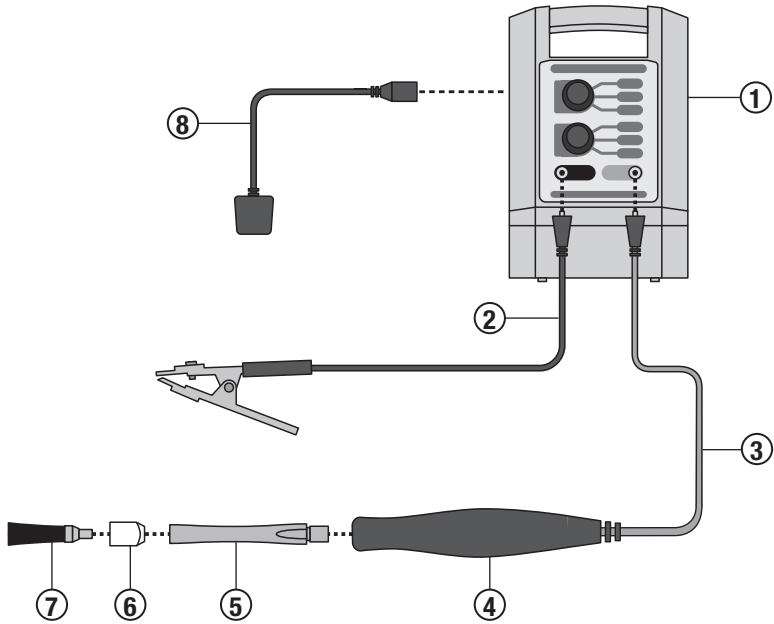

- ① TIG Brush Control Unit
- ② Clamp Cable
- ③ Handle Cable *
- ④ Handle
- ⑤ Wand
- ⑥ Shroud
- ⑦ Brush **
- ⑧ Power Cord

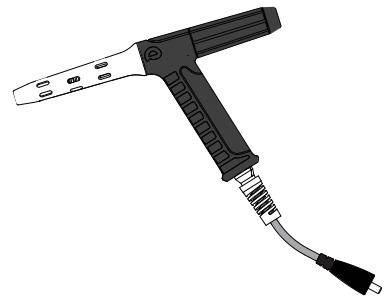

* Handle Cable may be replaced by Propel™ Torch (Optional)

** Single brush may be replaced by dual or quad brush adaptors.

S3 DESCRIPTION OF BASIC APPARATUS

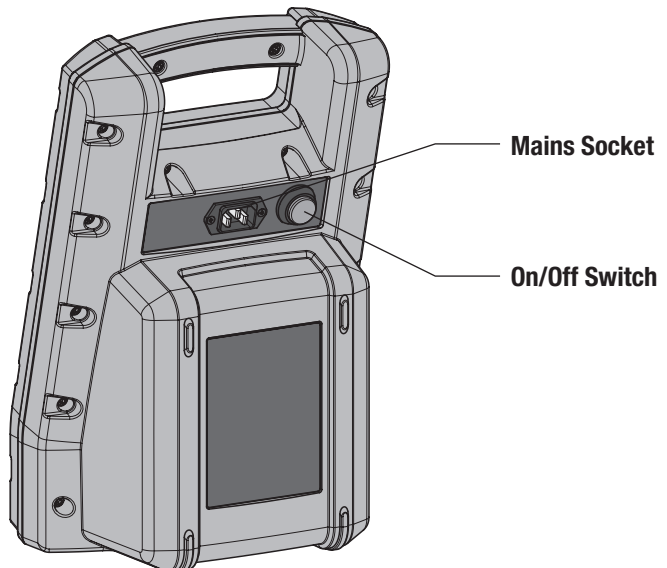
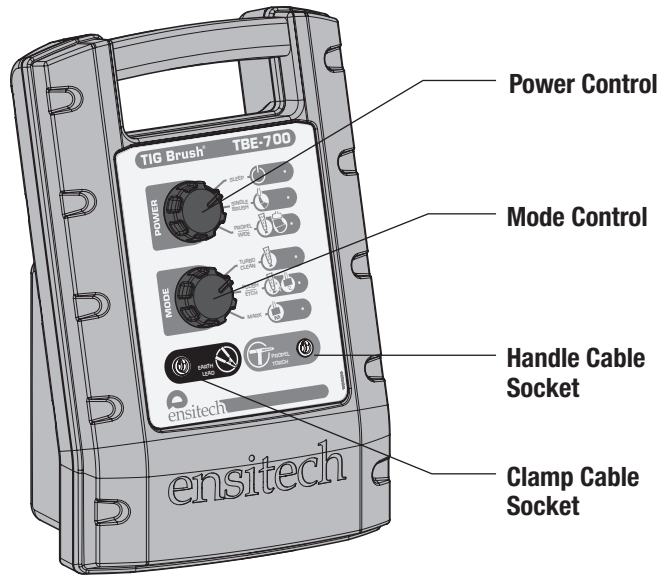

S4 OPERATION

4.1 PREPARATION

1. Inspect unit and all cables for damage before use.
2. Ensure the unit is dry.
3. Ensure the work environment is well ventilated and away from any combustible substances.
4. Ensure that cables do not present a trip hazard.
5. If the items to be cleaned are small, place the parts in a plastic container that can hold acidic fluids safely.
6. Parts will need to be sprayed with the recommended Ensitech neutraliser or washed down with water after cleaning. Ensure there is ready access to water and a suitable place for washing.



7. Wear suitable personal protective equipment as recommended in the SDS. The minimum requirement is for gloves to protect hands from the fluid, and goggles to prevent fluid splashing into the eyes.

4.2 ASSEMBLY

Refer to illustration on page 12.

1. Attach red handle cable plug to Handle cable socket of TIG Brush™ Control Unit.
2. Screw wand into handle.
3. Place shroud on brush and screw into wand.
4. Attach black clamp cable plug to Clamp cable socket of TIG Brush™ Control Unit.
5. Set POWER switch to “OFF”.
6. Attach power cord to mains outlet and TIG Brush Unit.
7. Attach clamp to workpiece.

4.3 CLEANING FLUID

Pour a small quantity of the Cleaning Fluid into a shallow bowl. Place the container close to the work because the tip will be dipped into the fluid regularly during operation.

S4 OPERATION

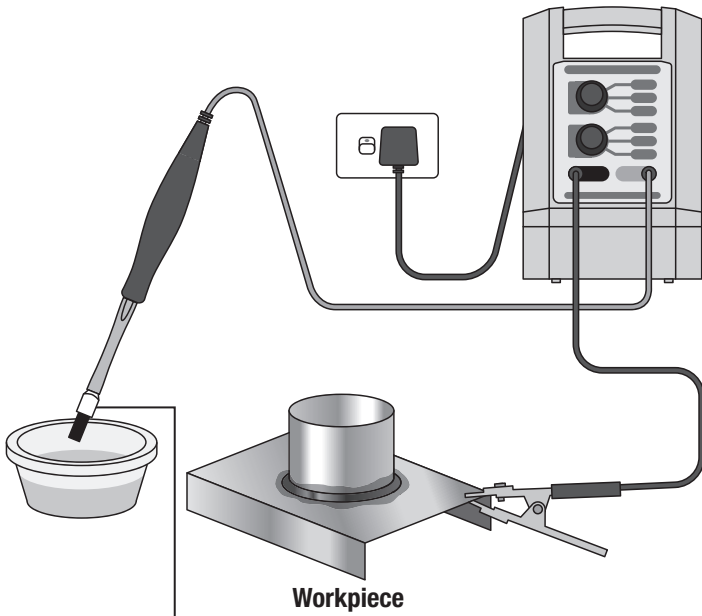

**Insulating shroud
must be used**

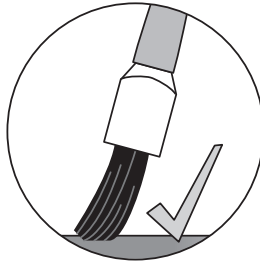

**For best performance
use tip of brush only**

S4 OPERATION

4.4 OPERATION

Refer to illustrations on pages 15 and 17.

1. Set POWER control to SLEEP. Always use this setting when connecting the clamp or changing the tip.
2. Ensure the power cord is connected to a suitable 110V or 240V AC power outlet and connected to the TIG Brush power socket.
3. Push the power button on the back of the unit to turn ON. The switch should be illuminated.



4. Make sure the brush tip has its insulating shroud and the insulation on the wand is undamaged.
5. Ensure the TIG Brush is switched on and all equipment is correctly connected as described above in section 4.2.
6. Select power level and operating mode using the rotary switches. See section 5 below for details.
7. Dip brush in cleaning fluid and apply brush tip to weld area to be cleaned. Use only recommended cleaning fluids, see S7.2.
8. Ensure brush and work area remain wet with the fluid during cleaning.
9. Apply brush only for as long as necessary to remove discolouration. Prolonged application may affect surface quality.
10. Some light sparking may occur where brush tip contacts workpiece, particularly on higher power settings, and this is normal. Excessive sparking for a prolonged time in one area may cause surface pitting.
11. When desired surface finish is achieved, turn the TIG Brush Power Control to SLEEP.
12. After use put the brush down on a non-flammable surface as it may be very hot.
13. Be careful touching the work as it may be hot.
14. Rinse thoroughly with clean water to remove all traces of cleaning fluid. To ensure acidic residue is removed, use the recommended Ensitech neutralising fluid, see S7.3.



S5 POWER AND GRADE SETTINGS

5.1 POWER SETTINGS

Choose the cleaning intensity required by selecting the appropriate setting using the Power Control.



SLEEP - Power is not transmitted to the brush.



SINGLE BRUSH - Use for light work and thin metals.



PROPEL / WIDE BRUSH - Use for ultimate control and speed, or covering larger surface areas.

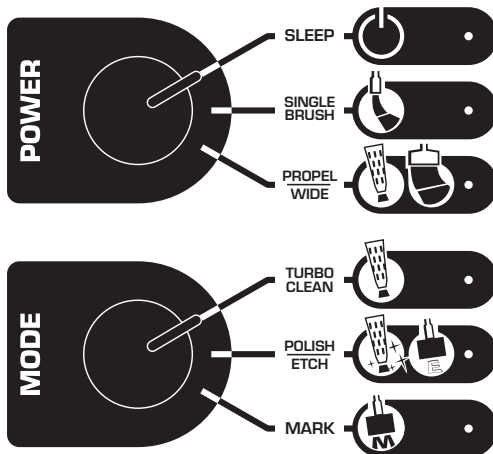

5.2 MODE SETTINGS

Choose the action to be performed by selecting the applicable mode with the MODE switch.



TURBO CLEAN - This mode provides the fastest cleaning at each power setting, but with prolonged use, may cause the surface to appear milky. Use POLISH / ETCH mode to rectify.



POLISH / ETCH - This mode provides metal polishing (rectify milky surface) as well as etching when used with the appropriate fluid and “Marking Head”.



MARK - This mode provides surface marking when used with the appropriate fluid in conjunction with the “Marking Head”.

S6 MAINTENANCE

6.1 MAINTENANCE

- When not in use, ensure the On/Off switch is OFF. This is confirmed when neither the LED in the switch on the back, nor the Standby LED in the front panel are illuminated.
- Rinse brush with water to remove excess cleaning fluid.
- At completion of a work shift, unscrew brush from wand. Remove the brush from the insulating shroud and rinse brush, shroud and end of wand with water to remove cleaning solution. Allow to dry before re-assembling.
- Rinse clamp with water to remove solution and prevent corrosion.
- Use a wet cloth to wipe fluid splashes off the TIG Brush control unit. After some time splashes and marks may accumulate and become difficult to remove.

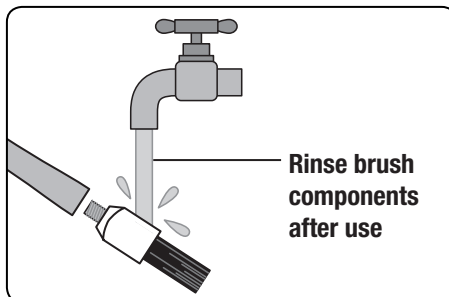
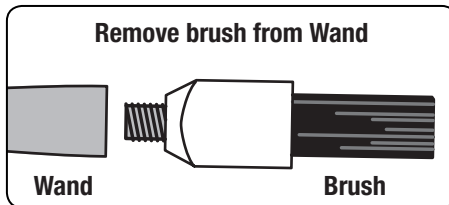

S7 CONSUMABLES

Consumable supplies are available from authorised TIG Brush distributors.

7.1 BRUSHES

The brush will wear down with use and should be replaced when the bristles reach approximately 12mm in length.

7.2 INSULATING SHROUD

The insulating shroud may become damaged or heat-affected. If this happens, replacement shrouds should be purchased.

7.3 FLUIDS

A range of genuine Ensitech fluids is available. Please check with your local TIG Brush distributor for details of fluids available in your region.

Types of fluids include:

- **Pre-Weld Cleaning Fluids:** to remove dirt and oil prior to welding to minimise contamination during welding.
- **Weld Cleaning Fluids:** for cleaning and, optionally, polishing. (Biodegradable and neutral fluids are available.)
- **Neutralising Fluids:** to ensure removal of all cleaning fluid residue.
- **Finishing Fluid:** to provide a clean, mark-free finish.
- **Marking Fluids:** can be used with custom stencils to indelibly mark metals.
- **Etching Fluids:** also used with the same stencils to give a deep custom etch to the metal surface.

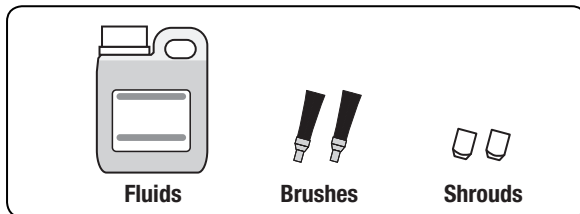

S8 TROUBLESHOOTING

If the TIG Brush is not operating correctly, please refer to the following trouble shooting guide before contacting your TIG Brush distributor.

8.1 FRONT PANEL POWER LIGHT NOT ILLUMINATED

- Ensure the On/Off switch on the back is ON. The red LED in the switch button should be on.
- Ensure the power cable is pushed completely into the socket on the back of the TIG Brush.
- Ensure power is present at the power point (possibly by plugging in another appliance, such as an inspection light).

S8 TROUBLESHOOTING

8.2 FRONT PANEL POWER LIGHT ILLUMINATED BUT UNIT NOT OPERATING

- Ensure the Power Control is not set to SLEEP.
- Ensure the cables are securely plugged into the front of the TIG Brush.
- Ensure the clamp is gripping the work securely. Sometimes the clamp position may need adjusting to make a good contact. If dirt or debris has built up on the clamp, clean it as this may prevent a good contact being made.
- Ensure the brush is wet with fluid.
- Ensure that the work is conductive. If the metal has a plastic film or a thick layer of oxide, the current cannot flow through the work. A mechanical or chemical method may need to be used to remove any insulating film before the TIG Brush can be used.
- Examine all cables for damage and ensure they are properly connected.
- Ensure the brush is securely screwed into the wand.
NOTE: Be careful when checking, as a loose connection may be extremely hot.
- Check screw threads on the handle, wand and brush for dirt and contamination and clean if required.



Contact your TIG Brush distributor or visit the website for more help www.tigbrush.com

S9 WARRANTY

WARRANTY AGAINST MANUFACTURING AND MATERIAL DEFECTS

WARRANTY AGAINST DEFECTS

This product comes with Ensitech Pty Ltd's (we/Ensitech) warranty against defects that are a result of faulty manufacturer workmanship or materials. The details and conditions of this warranty are set out below.

PERIOD OF WARRANTY

You may claim on this warranty if you notify Ensitech of the defect in the manner set out below and if you comply with the other procedures and conditions of this warranty, within:

- in the case of the TIG Brush™ control unit, two years; or
- in the case of clamp cables or handle cables, three months, of the date of purchase of the product by you.

WHO CAN CLAIM UNDER THIS WARRANTY?

This warranty applies to and can be exercised by the original purchaser of the product only. This warranty is not transferrable to any other person or party under any circumstances.

THINGS YOU MUST DO BEFORE A CLAIM IS MADE

Before making a claim under this warranty you must:

- register your purchase of this product on-line within 60 days of purchase date by following the instructions and prompts at www.tigbrush.com/warranty and
- follow the trouble-shooting procedure by contacting Ensitech by email, by letter or by phone at the contact points noted below. We will advise you of the procedures that need to be followed to check the product. If, having followed that procedure, the product is still considered defective, you may make a claim under this warranty

WHAT THIS WARRANTY DOES NOT COVER

If Ensitech reasonably considers that any of the following situations are present, this warranty does not apply. The situations to which this warranty does not apply are:

- normal wear and tear;
- any cosmetic damage, such as scratches to paint work etc;
- damage to consumable products, such as brushes, insulating shroud and wand;
- damage caused by the use of consumables or accessories not manufactured by Ensitech or its authorised contract manufacturers, whether or not purchased from an Ensitech distributor or reseller;
- to a product that has been altered or repaired by a person other than Ensitech or its authorised repairers;
- any product where the product's serial number is no longer present or visible;
- loss or damage caused by factors beyond Ensitech's control including, but not limited to, damage or failure due to power fluctuations, overload, excessive heat, dust, water immersion or contact with water or humidity;
- damage or defects caused to the product due to unusual, abnormal, non-recommended or negligent use of the product;

- damage due to dropping, collision, impact or other accident;
- any product which has not been kept clean or has not been maintained or stored according to any care or operating instructions provided with the product; or
- consumables which are past their use by date.

PROCEDURE FOR MAKING A CLAIM

If you have followed the trouble shooting procedure noted above and still consider the product to be defective, you may make a claim made by contacting Ensitech by email or by letter at the address noted below. With that notice you must also provide us with the following information in writing:

- Your name or company name (if applicable);
- Your address;
- Your email address;
- Your telephone number;
- Contact name;
- Machine type, model number and serial number;
- Proof of your purchase of this product, such as your receipt or supplier's invoice; and
- A detailed description of the defect you believe the product to have.

Ensitech will advise whether you must send the faulty product to Ensitech or its authorised repairer, or to your distributor or reseller. **Please note that if you have the Product repaired by someone other than Ensitech or its authorised repairer, you cannot claim under this warranty.**

You must bear the cost of transporting the product to Ensitech, the distributor/reseller or its authorised repairer and all other costs of exercising your rights under this warranty.

WHAT WE WILL DO TO HONOUR THIS WARRANTY

Upon delivery to us we will assess the product to determine if the fault or problem is covered by this warranty. We will advise you by email or letter whether the fault is covered by this warranty. If the warranty applies, at our option, we or our authorised repairer will repair or replace the product with a new product or a product of the approximate age of your product. We will do these things within a reasonable period after receipt of the product and all required information from you.

YOUR OTHER RIGHTS AND REMEDIES

This warranty against defects is provided in addition to other rights or remedies you, as a consumer, may have under a law in relation to this product.

If you purchased this product in Australia: Our goods come with guarantees that cannot be excluded under the Australian Consumer Law. You are entitled to a replacement or refund for a major failure and for compensation for any reasonably foreseeable loss or damage. You are also entitled to have the goods repaired or replaced if the goods fail to be of acceptable quality and the failure does not amount to a major failure.

Model: _____ **Serial No.** _____

Date of Purchase: _____

Purchased from: _____

